

Detection of IED Using Nanotechnology

Muthukumar K. & Devi Mala E.

Abstract — Security is the key factor of world's peace. Terrorists are using Improvised Explosive Devices (IED) for their attacks. Identification of IED is not simple, the only way to identify IED is by using chemical sensors but using a chemo sensors is quiet complex and more expensive. So we brought nano sensors to identify it. Using nano sensors is much efficient & highly sensitive at the single molecule level. Nano materials provide a strong potential to create sensors for detecting explosives. Electronic noses, nano wire / nano tube and nano material device are nano sensor concepts with strongest potential to form detecting devices & also to detect the conventional bombs, plastic explosives and grenades. Generally IED can be identified by trained dogs but it is quiet difficult to maintain and using in sensational places. Electronic nose is mainly composed of chemical sensor system, sampling system and a pattern recognition system as a neural network. This composited detector can sense the odour difference caused by explosives and converts it to signals. For instance electrical conductivity in a nanotube changes due to interacting with molecules of an explosive analyze, as a result of highly selective adsorption. Nanomechanical effects induced by molecular adsorption offer unprecedented opportunities for trace explosive detection. Though nano is also implied in some screening technologies, really developed sensors are nanosensors as it have advanced sensitivity and selectivity of explosive detection systems. There are some challenges in detecting explosives such as fabrication of sensors, providing stability, sampling and reliable calibration and identification of pattern in complex changing backgrounds. Overcoming the difficulties nano sensors combined with advances in conventional detection platforms have high efficiency and stability to detect by advanced solution concluded in the paper. All governments of world have now realized the significance of explosive threats.

Index Terms — IED detection, Carbon Nano Tube, Electronic Nose.

1 INTRODUCTION

1.1 Improvised Explosive Device (IED) threats

An Improvised Explosive Device (IED) is defined as “a device placed or fabricated in an improvised manner incorporating destructive, lethal, noxious, pyrotechnic, or incendiary chemicals and designed to destroy, incapacitate, harass, or distract.” These rudimentary bombs generally consist of commonly found, non-military materials. Improvised Explosive Devices have existed since the Chicago Haymarket Riot in 1886. However, IEDs currently provide the largest obstacle to coalition forces fighting in the Middle East. Terrorists construct these small devices and inflict grave damage upon military equipment and personnel. American casualties are not immune to the effects of IEDs. IED attacks account for over 60% of Operation Iraqi Freedom (OIF) casualties and 50% of Operation Enduring Freedom (OEF) casualties. The first reported IED attack on American forces in Iraq occurred on March 29, 2003. Since that first Iraqi attack, there have been over 81,000 IED attacks and over 25,000 in IED attacks in 2007 alone.²



Fig. 1 IED Explosion

Insurgent cells constructing IEDs are small, highly trained groups that remain as hidden as possible. The IED groups consist of six to eight people, including a financier, bomb maker, emplacer, triggerman, spotter, and cameraman. Despite US-led efforts to find these cells, new cells repeatedly form in Iraq. Estimates include 160 bomb-making cells in Iraq. Although common IED threats include roadside bombs, suicide bombers are another emerging problem in the IED arena. Suicide bombers carrying Personal-borne IEDs (PBIEDs) are extremely hard to detect or stop. Because no IED emplacement is necessary, a suicide bomber can quickly strap on an IED-laden vest and move to the kill zone. Placed in the proper urban environment, this weapon is capable of inflicting serious structural damage and killing hundreds of people in mere seconds.²

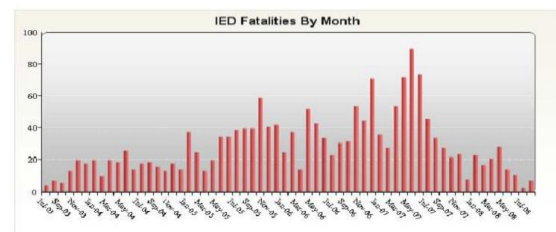

Fig. 2

IED Fatalities by Month Market for nanotech products will grow exponentially

Analysts estimate that the market for products based on nanotechnology could rise to several hundreds of billions by 2010 and exceed one trillion after. Nanotechnology is expected to impact upon virtually all technological sectors as an “enabling” or “key” technology, especially upon:¹²

- Medicine and health
- Information technology

- Energy production and storage
- Transportation, vehicles and infrastructure
- Food, water and the environment
- Instruments
- Security

Next to the ongoing progress in nanoelectronics, expectations are especially high for:

- Nano-bio applications
- Nano based sensors
- and nanomaterials in the longer term (10 years)¹²

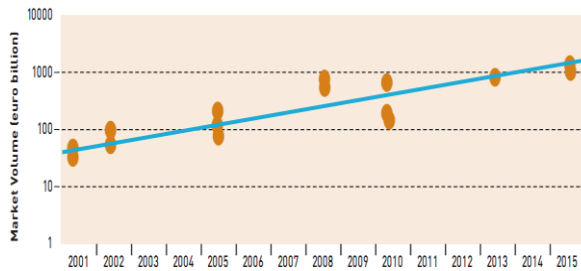

Fig. 3 Exponential market growth for nanotech products¹⁵

Advent of nano technology, research is under way to create miniaturized sensors. Miniaturized sensors can lead to reduced weight, lower power consumption, and low cost. Materials such as inorganic semi conductors are used in making nanosensors.

Today, numerous nano-enabled sensor designs are being pursued to improve industrial process monitoring and leak detection, environmental monitoring (air and water quality), food-quality surveillance, and medical diagnostics, and to enable the reliable, real-time detection of chemical, biological, radiological and nuclear hazards for military and anti-terrorism applications.

However, the discovery of carbon nano tubes (CNTs) has generated keen interest among researchers to develop CNT-based sensors for many applications. The application of CNTs in next-generation of sensors has the potential of revolutionizing the sensor industry due to their inherent properties such as small size, high strength, high electrical and thermal conductivity, and high specific surface area.

CNTs are hexagonal networks of carbon atoms of approximately 1nm diameter and 1 to 100 microns of length. They can essentially be thought of as a layer of graphite rolled-up into a cylinder. Depending on the arrangement of their graphene cylinders, there are two types of nanotubes: single-walled nanotubes

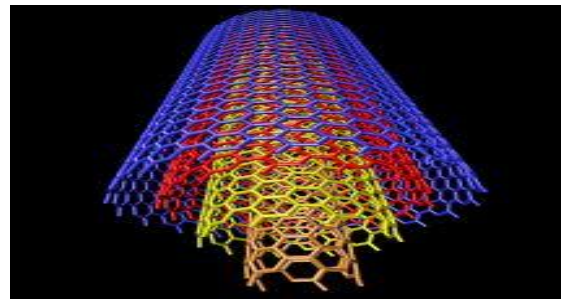
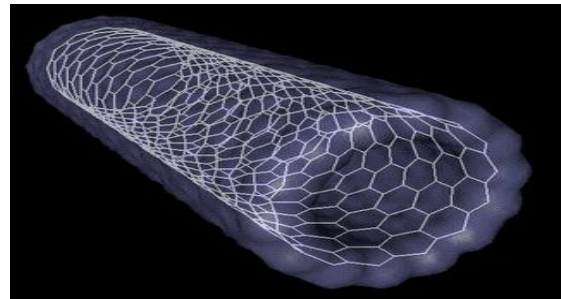

Fig. 4 single-walled nanotubes (SWNTs) and multi-walled nanotubes (MWNTs)

(SWNTs) and multi-walled nanotubes (MWNTs). SWNTs have only one single layer of graphene cylinders; while MWNTs have many layers (approximately 50), as shown in Figure 4.¹⁸

2 OBJECTIVES OF THIS PAPER

- 2.1 Implementation of Electronic Nose technique in explosives detection.
- 2.2 Developing a Nano Chemo Sensor (NCS) using nano technology.
- 2.3 Using Carbon Nano Tube (CNT) based chemical sensors for the detection of hidden bombs and chemical bombs.
- 2.4 Overcoming the challenges of IED detection.

2.1 Implementation of Electronic Nose Technique:

Electronic noses are nano wire, nano tube and nano mechanical devices are nano sensor concepts with the strongest potential to form viable technological platforms for trace Explosive detection. At present, dogs have been trained and used successfully for sniffing out hidden explosives; however, dogs are expensive to train and are easily tired. The electronic nose technique can mimic the bomb-sniffing dogs without their drawbacks. An electronic nose device is usually composed of a chemical sensing system, sampling system and a pattern-recognition system, such as an artificial neural network as shown in the figure 5.

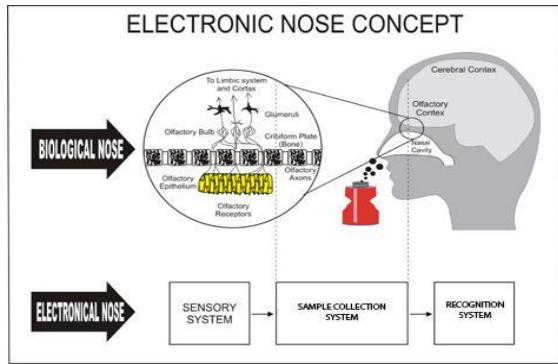

Fig. 5 Electronic Nose Concept

The sensing system consists of an array of sensors, with each sensor in the array giving a different electrical response for a particular target vapour introduced into the sensing chamber. The combined output from the sensor array forms a finger print, or signature, that is unique for a particular odour. Pattern recognition techniques based on principal component analysis and artificial neural networks were developed for learning different chemical signatures.³

2.2 Developing a Nano Chemo Sensor (NCS) using nano technology

Preparing a nano chemo sensor is possible by nano technology only. To develop a sensor its electrical response, optical properties and interaction of molecules should be known.

2.2.1 Electrical response

Generally CNTs have a very high surface area to volume ratio and unique electrical and optical properties that can be exploited for highly sensitive molecular adsorption detection. For instance (Figure 6) electrical conductivity in a nanotube changes drastically due to interacting with molecules of an explosive analyte, as a result of highly selective adsorption.

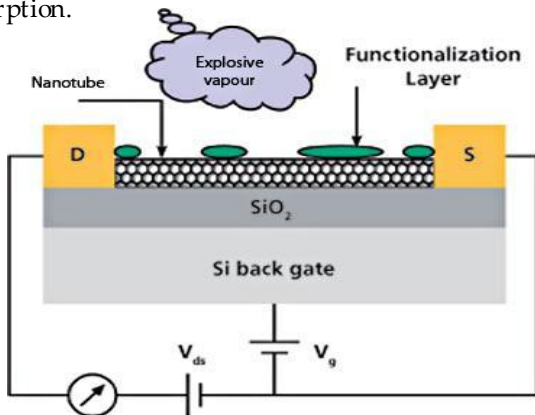

Fig. 6 Illustration of nano wires sensor platform

2.2.2 Formation of nano chemical sensors

Nanomechanical effects induced by molecular adsorption offer unprecedented opportunities for trace explosive detection. Nano mechanical sensors such as cantilever beams have many modes of operation. For example, when explosive molecules bind to the detection molecules on the cantilever made in nano-structured silicon, this will induce a surface stress and the cantilever will bend (Figure 7). Differential adsorption is obtained by immobilizing a selective layer on one side of the cantilever. Nano cantilevers are expected to provide ultra-high-sensitivity mass detection, ultimately approaching the single-molecule level.⁹

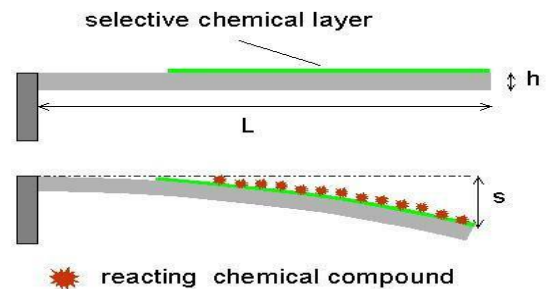

Fig. 7 Molecular adsorption induced bending a cantilever

2.2.3 Detection of IED bombs by chemo sensors;

Recent advances in nano materials research provide good potential to create sensors for detecting explosives like IED providing sensitivity at the single molecule level. Also, due to reduced dimensions, nano materials offer capability of incorporating multiple sensors capable of detecting multiple threats simultaneously. The ability of nano enabled technologies to effectively detect explosives on people and their belongings, as well as the expectations of the public for openness and speed will likely be key drivers for their successful implementation.¹⁶

2.3. Using Carbon Nano Tube (CNT) based chemical sensors for the detection of hidden bombs and chemical bombs

CNT based sensors can be potentially applied in defense and homeland security. They can be deployed in unmanned defense systems such as unmanned aerial vehicles. The meaning of security here is security from bombs and weapons at the ports of entry.

As mentioned earlier CNT based chemical sensors can be used as electronic noses to detect hidden bombs, chemical weapons in luggage, vehicles, and aircraft. However, there are some health hazards considerations associated with subjecting passengers to some types of screening technologies currently used for explosive detection. For example, certain types of explosive detection screening equipment may expose individ-

uals to mild radiation. The use of explosive detection systems based on carbon nano tube based sensors will help to reduce the above mentioned implications posed by existing scanning equipment.⁸

2.4 Overcoming the challenges of IED detection

Explosive detection with high sensitivity and selectivity is a difficult challenge because of a number of operational factors, such as the acute shortage of explosive molecules that can be collected in a reasonable time and lack of selectivity because of interference from other molecules.

2.4.1 Challenges

Most of existing technologies that utilize nano wires and nano tubes in the fabrication of sensors have fallen short of controlling the growth of the nano particles of a given size with minimal defects and the capability to manipulate and align these nano wires based on the application. Also, the characterisation of the material properties as a part of the device remains mainly unaddressed by current technologies. Challenges to unlock the potential of the electronic nose technology for viable explosive detection applications relate to providing stability, sampling and reliable calibration and identification of patterns in complex changing backgrounds. In addition to technical challenges for developing nano enabled detection methods there are several overarching operational and policy considerations impacting the deployment of these technologies for protecting public from terrorism threats.¹⁸

2.4.2 Position of EU

Governments in all regions of the world have now realized the significance of the threats posed by illicit use of explosives and responded by increasing support of R&D activities aimed to significantly improve the explosive detection capability to prevent and respond to existing and potential threats. In 2008 the EU Council has adopted the EU Action Plan on Enhancing the Security of Explosives. The Action Plan is built on three pillars, prevention, detection and response, containing specific measures on explosive precursors, the supply chain (storage, transport, traceability) and detection. A set of 48 specific horizontal actions, along with deadlines for their implementation concerning public security, complements and consolidates the three pillars. Funding is made available for measures falling under the Action Plan by way of two programmes;⁵

- The Prevention of and Fight against Crime programme
- The 7th Framework Research Programme.

3. SOCIAL RELEVANCE & USEFULNESS:

Increasing terrorism that operates across a broad spectrum involving political, economic, social, and informational activities. Unable to attain victory through military action, non-state actors attack asymmetrically. Effective stabilization operations require knowledge of how insurgent networks effectively influence and are influenced by dynamic cultural and social factors as well as insight into how a wide variety of actions will result either in improvement or continued degradation. Networks are the systems of people, facilities, supplies and finances that terrorists use to produce, transport or employ IEDs.¹

To effectively attack an IED network one must understand and penetrate the strategic, operational, and tactical environments where IED operations are conducted. This can be difficult because the adversary makes use of individuals who blend into a complex, often urbanized environment. In this environment the enemy is virtually undetectable and can remain hidden for extended periods of time unless we can force him to move, shoot, or communicate in reaction to us. To do this, our Concepts of Operations must have the coordinated ability to reduce the impact and influence of an adversarial network simultaneously at several small points or nodes or at least force them to maneuver into a presumed safe haven. Such unplanned migrations reduce adversary options and force them to interact among themselves, further exposing their networks.

The risk of a terrorist attack involving use of explosives remains high in Europe. These attacks may cause severe consequences including human casualties, and widespread disruptions of critical infrastructures and public confidence.¹

4. ADVANTAGES OF THE PROJECT:

- Protect the public.
- High sensitivity and selectivity.
- Ability to lower the production and deployment costs of sensors.
- Portability, Safety, Robustness.
- Small Size offers better signal to noise ratio.
- Reliability, Reproducibility
- Upgradability.¹⁸

5. FUTURE DEVELOPMENTS:

In future Nano wires and Nano pore can be used instead of Nanotube also the technology is adopted with wireless communication systems. Using this detection technique is simple but it is restricted with distance of sensing so implementation of new ideas to have high distant sensitivity is my ongoing process. To reduce the damages and increasing security using the electrical signals produced from the Nanosensors.

6. CONCLUSION:

Exploitation of nanotechnology is already part of society, with high investments worldwide many nano products already exist on the market (additives in cosmetics, paints, polymers, catalysts, filters). Some products are expected to come soon (within 5 years), especially wireless tags and nanosensor systems. Others are expected to come later, in a time frame of 5-15 years (high-strength nanomaterials, smart/adaptive materials). More and more nanotechnology is being converged with other technologies, especially biotechnology, information technology and cognitive science. The defence organization can gain a lot of benefit from these new technologies and should actively participate in these developments. The spread of terrorist events over the globe in the last decade has emphasized the importance of detecting concealed explosives and led to calls for new advanced technologies to protect the public. Because most explosives release little vapour, it is not possible to detect them effectively by methods widely used on other chemicals.

Nano scale effects can be exploited to offer the possibility of sensors that satisfy all the requirements for explosives trace detection. High sensitivity and selectivity, combined with the ability to lower the production and deployment costs of sensors, is essential in winning the battle on explosives based terrorism. It is expected that the detection of explosives using CNT based sensors will be explored in future as the interest of the nano technology research community in this field increases. However, CNTs have yet to cross many technological hurdles in order to fulfill their potential as the preferred material for sensor applications.

7. REFERENCES:

1. Niraj Sinha, Jiazhi Ma, and John T.W. Yeow, "Carbon Nanotube-Based Sensors" 2006.



Devi Mala E. obtained a B.E. degree in Electrical & Electronics engineering from Thiyagarajar college of engg. & Tech., ANNA UNIVERSITY, Chennai, India, in 2004 & M.E. Degree in the Department of Applied Electronics at Jayaram College of Engg. & Tech., ANNA UNIVERSITY, Chennai, India. He is current research interests are in the field of devel-

2. Detection of ied emplacement in urban environments by Matthew O'Hara "september 2008".
3. The nose knows: developing advanced chemical sensors for the remote detection of improvised explosive devices in 2030 by julie v. Guill, major, and usaf "april 2009".
4. Carbon nanotube-based sensors by niraj sinha, jiazhi ma, and john t. W. Yeow "journal of nanoscience and nanotechnology vol.6, 573-590, 2006".
5. Recent advances in trace explosives detection instrumentation by david s. Moore, "26 may 2007".
6. Nano sensors: evolution not revolution Yet., by suzanne shelley - contributing editor, "www.aiche.org/cep, june 2008".
7. Conductometric gas nanosensors by girolamo di francia, brigida alfano, and vera la ferrara, "hindawi publishing corporation journal of sensors volume 2009".
8. Carbon nanotube-spm-probes single / double wall cnt-spm-probes by v. Bouchiat, h. Guillou, b.vianay, o. Krause, e. Plannus, m.block, a.-m. Bonnot, j.f. Allemand, v. Croquette, "afm biomed 2008".
9. Julie V. Guill, Major, USAF, "The Nose Knows: Developing Advanced Chemical Sensors For The Remote Detection Of Improvised Explosive Devices In 2030"(2008).
10. Liming Dai, Prabhu Soundarajan, and Taehyung Kim, "Sensors and sensor arrays based on conjugated polymers and carbon nanotubes"2002.
11. <http://www.wifinotes.com/nanotechnology/what-is-atomic-force-microscope.html>.
12. <http://nanotechinkorea.free.fr/english/nano.php>.
13. Pekarek J. Ficek R. Vrba R. Magat M. "Electrodes modified by carbon nanotubes for pressure measuring"2009.
14. Behrouz Arash and Quan Wang, "Carbon Nanotube-Based Sensors for Detection of Gas Atoms"(011).
15. <http://www.survivalconsultants.com/article-breachbangclear-mrapjltv.html>.
16. http://en.wikipedia.org/wiki/Improvised_explosive_device.
17. <http://wikiroof.blogspot.com/2011/07/carbon-nanotubes-and-future-of-solar.html>.
18. Nanotechnology innovation opportunities for tomorrow's defence., "Frank Simonis & Steven Schilthuizen".

Muthukumar K. obtained a B.E. degree in Electronics & Instrumentation engineering from RVSCET, ANNA UNIVERSITY, Dindigul, India, in 2007, and currently pursuing M.Tech. Degree in the Department of Embedded Systems Technology at Veltech University of Chennai, India. eloping nano devices based sensors.



oping nano devices based sensors.